

HOM Characterization for Beam Diagnostics at the European XFEL

N. Baboi, DESY (for the HOM team)

HOMSC2016, Warnemünde, 22 Aug. 2016



- HOM-based diagnostics in SC accelerating cavities
 - Principle
 - Experience at FLASH

- The European XFEL
 - Spectra of 1.3 GHz cavities in the E-XFEL
 - Beam measurements in 1.3 GHz cavities in the E-XFEL injector

- Summary

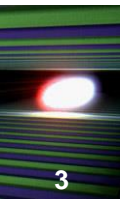

- HOM-based diagnostics in SC accelerating cavities
 - **Principle**
 - Experience at FLASH

- The European XFEL
 - Spectra of 1.3 GHz cavities in the E-XFEL
 - Beam measurements in 1.3 GHz cavities in the E-XFEL injector

- Summary

HOM-based Beam Diagnostics in SC Cavities: Principle

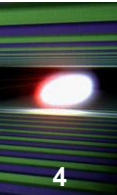

- HOMs carry information about the beam properties
⇒ they can be used to monitor the beam
- The strength of the excited dipole modes depends linearly on the beam charge and position: $q \cdot r \cdot (R/Q)$
- The timing of excited modes depend on beam arrival time (beam phase)

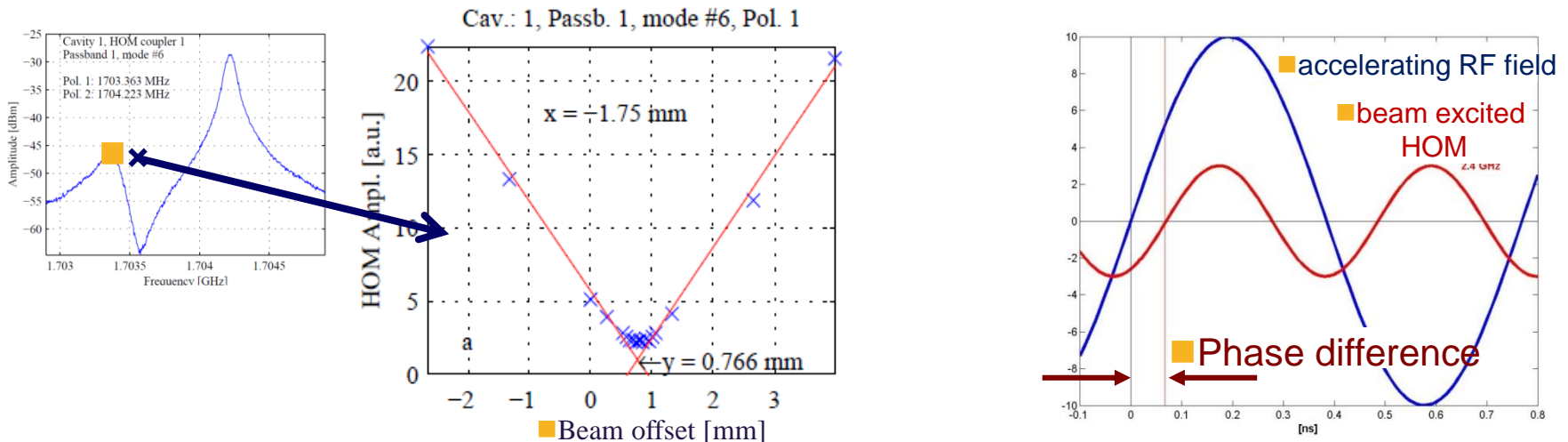

HOM-based Beam Diagnostics in SC Cavities: Benefits

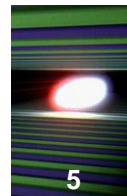

- **Align the beam** based on the signals which can damage beam quality, therefore reduce the (long-range) wakes
- Measure the transverse **beam position**
- Measure the transverse **cavity alignment** in the cryo-module

- Direct, on-line measurement of **beam phase** wrt RF phase

- Does not require additional vacuum components, therefore relatively cheap

- HOM-based diagnostics in SC accelerating cavities
 - Principle
 - **Experience at FLASH**

- The European XFEL
 - Spectra of 1.3 GHz cavities in the E-XFEL
 - Beam measurements in 1.3 GHz cavities in the E-XFEL injector

- Summary

HOM-based Beam Diagnostics in SC Cavities: Experience at FLASH

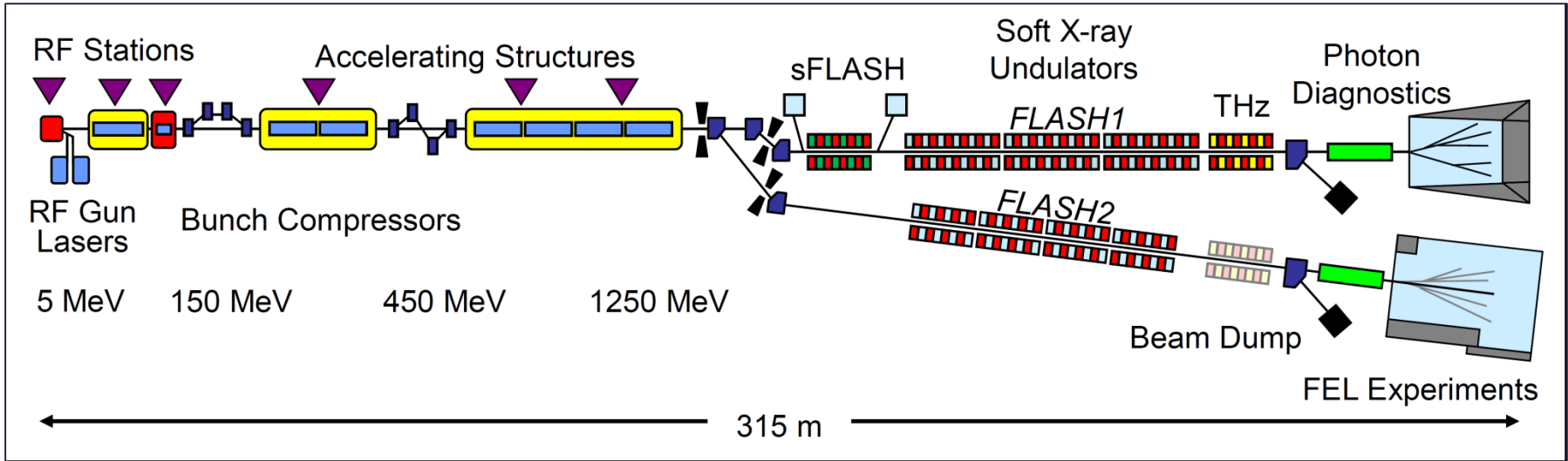
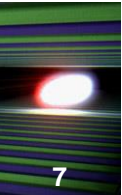

TESLA (1.3 GHz) cavities

3rd harmonics (3.9 GHz) cavities

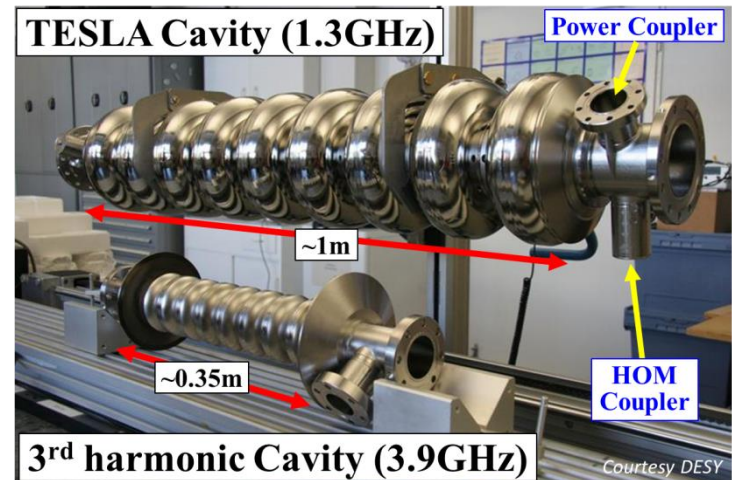

Experience at FLASH: 1.3 GHz cavities

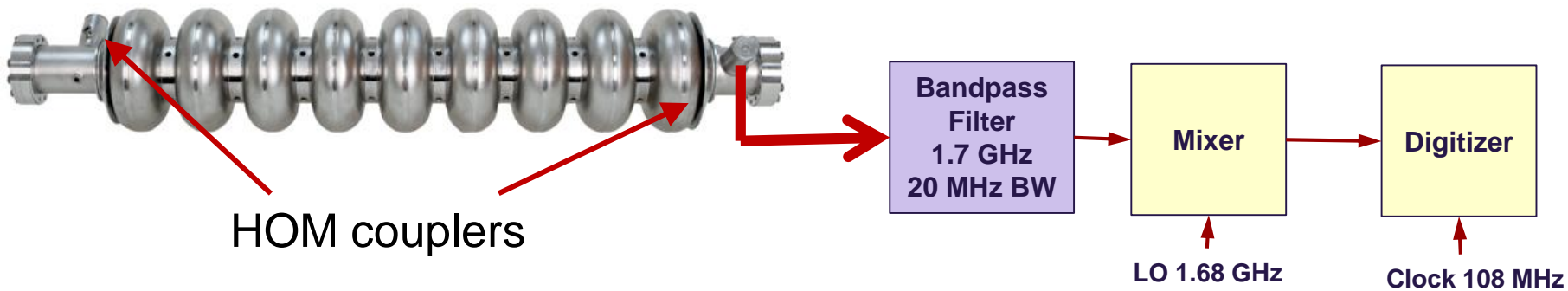
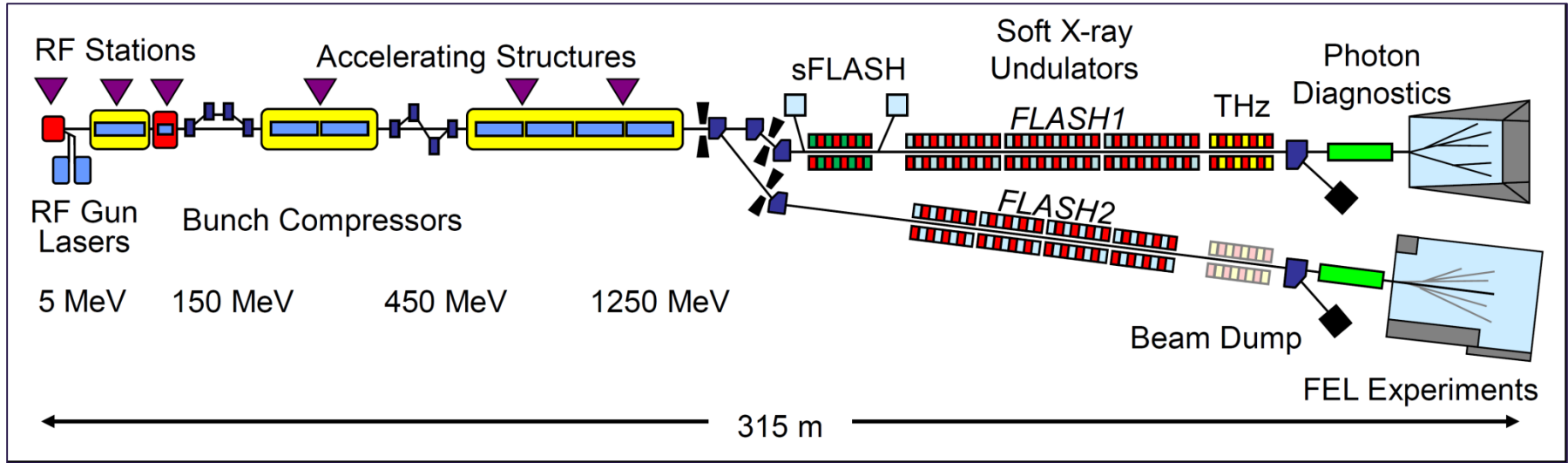
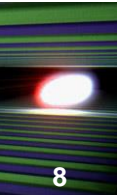

- HOM electronics installed in 5 cryo-modules in FLASH

Joe Frisch, SLAC

Experience at FLASH: 1.3 GHz cavities

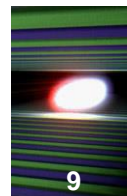

- Showed resolution < 10um rms

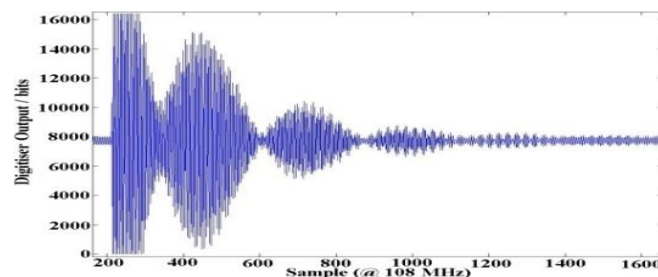
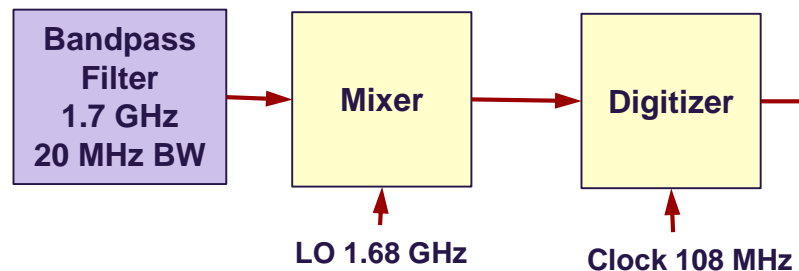
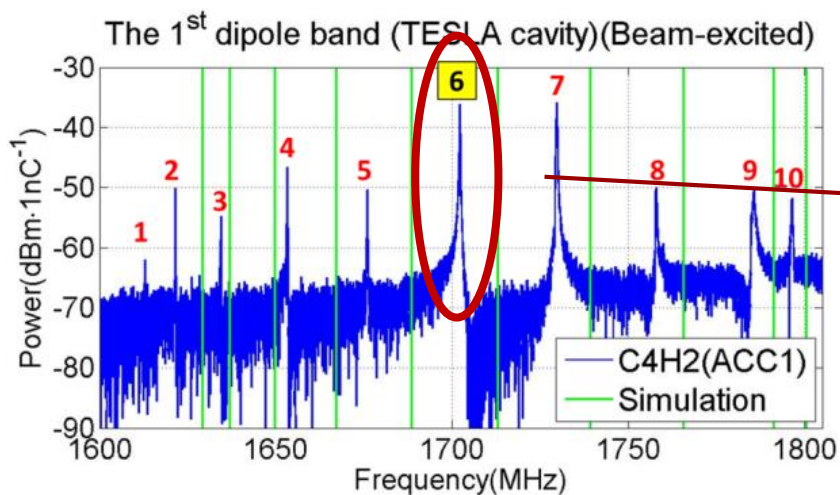

Experience at FLASH: 3.9 GHz cavities

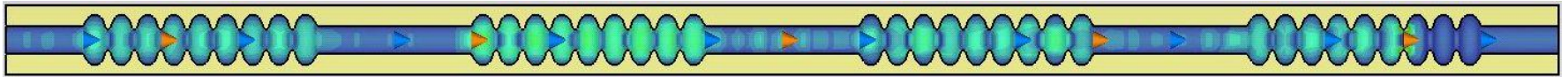
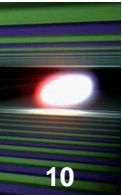

- Use propagating and trapped modes
- Concept based on extensive studies within EuCARD (UMAN, UROS, DESY)

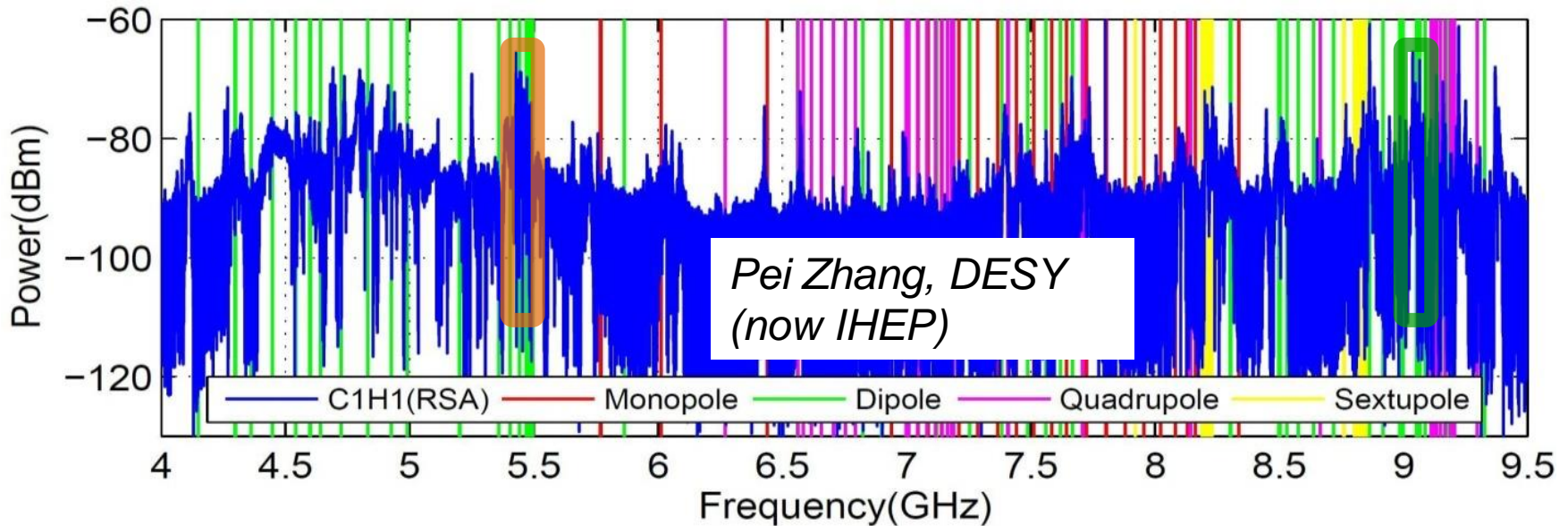
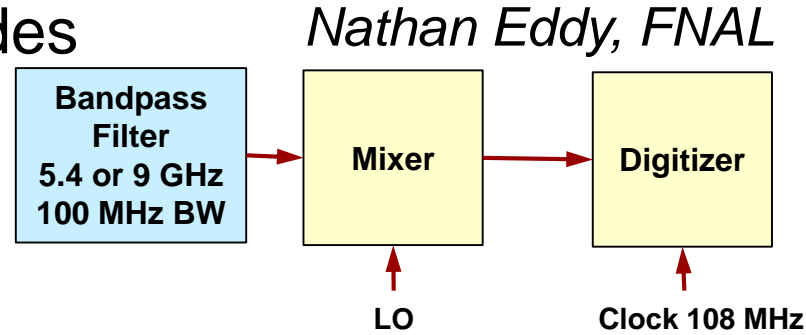

- HOM-based diagnostics in SC accelerating cavities
 - Principle
 - Experience at FLASH

- **The European XFEL**
 - Spectra of 1.3 GHz cavities in the E-XFEL
 - Beam measurements in 1.3 GHz cavities in the E-XFEL injector

- Summary

The European XFEL: Overview

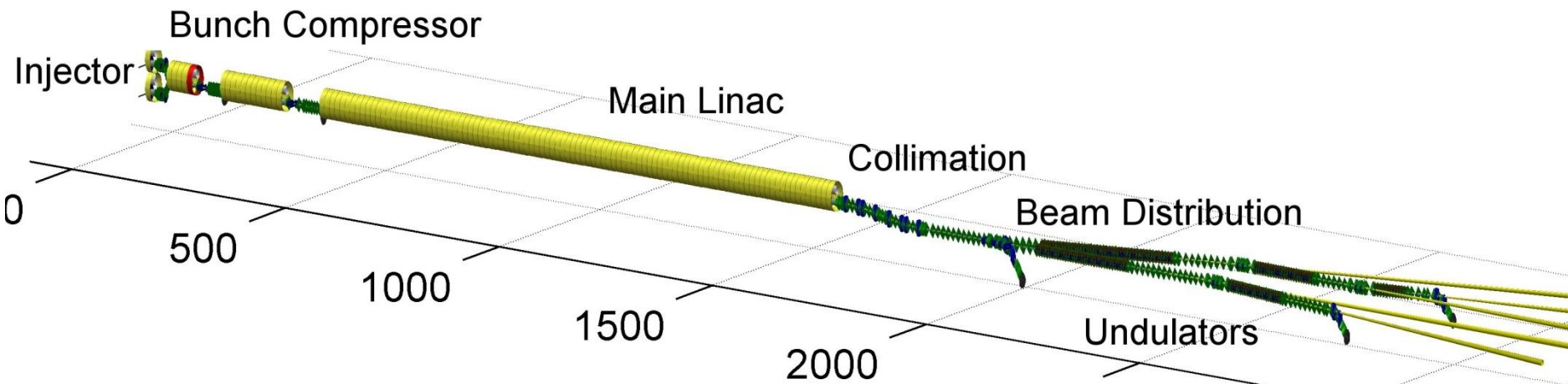
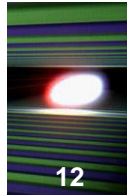

- 17.5 GeV; up to 2700 Bunches/RF Pulse @ 10 Hz; 0.02-1 nC
- 101 TESLA modules
- One 3rd harmonic module with 8 cavities
- Injector started operation in Dec. 2015
- First beam through linac expected before end of 2016

E-XFEL: Plans for HOM-based Beam Diagnostics in 1.3 GHz cavities

■ Electronics under design

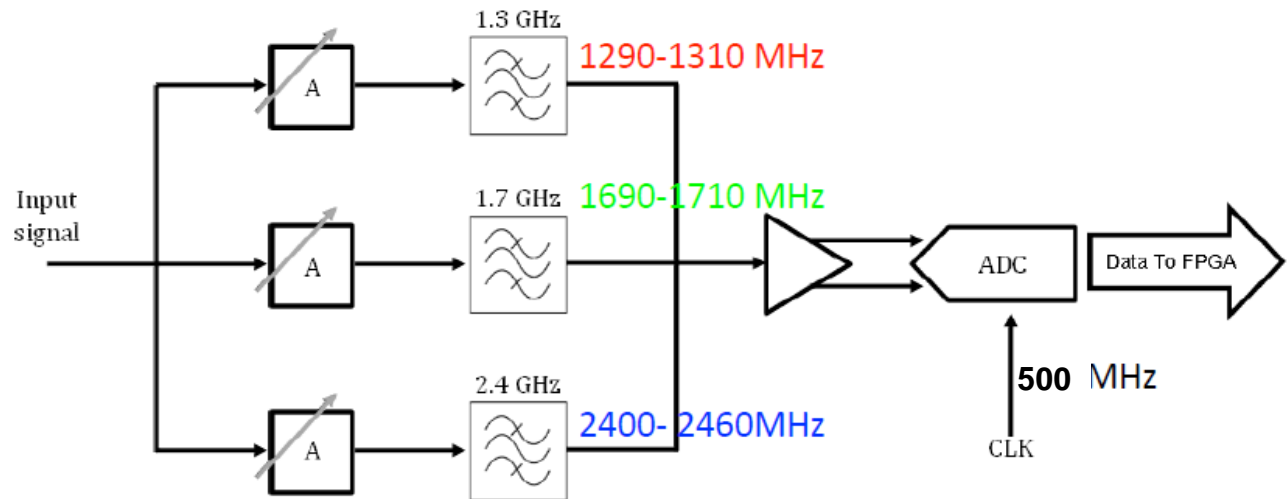

■ Multiple filter

- selects 1.3 and 2.4 GHz monopole modes from spectrum
- Also 1.7 GHz dipole mode for beam position monitoring

■ Direct sampling: No downconversion

E-XFEL: Plans for HOM-based Beam Diagnostics in 3.9 GHz cavities

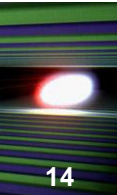

- Electronics under design: same principle as in FLASH
- HOM-BPMs at 3.9 GHz cavities at the E-XFEL more challenging mainly due to
 - 8 coupled cavities (4 at FLASH)
 - Different orientation of cavities
- Object of task within EuCARD-2 (UMAN, UROS, DESY)

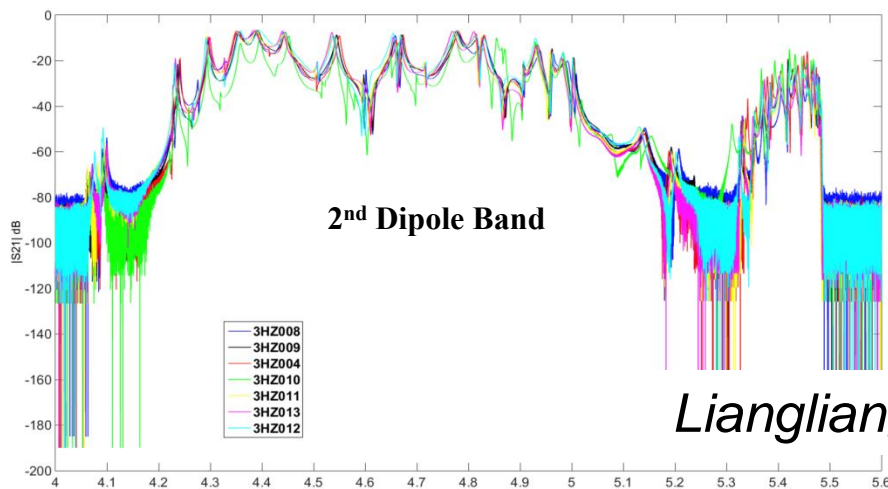

Liangliang Shi, DESY

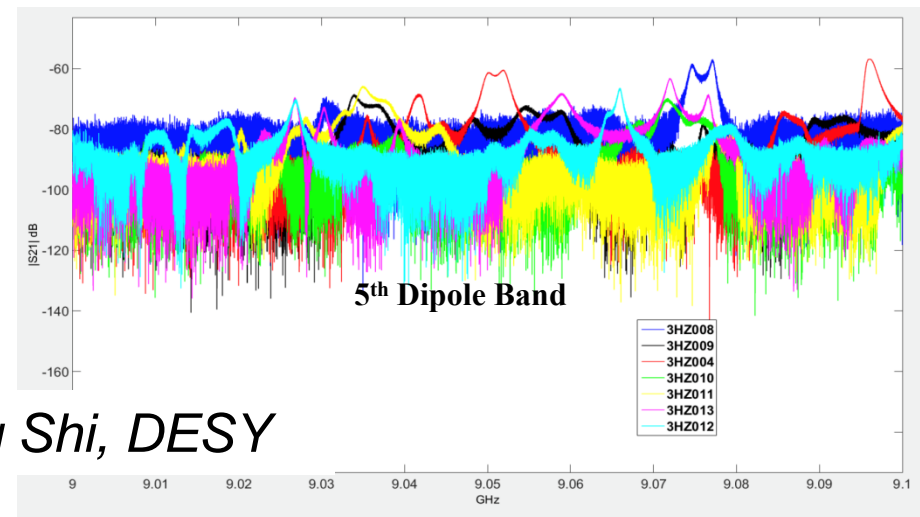

- HOM-based diagnostics in SC accelerating cavities
 - Principle
 - Experience at FLASH

- The European XFEL
 - **Spectra of 1.3 GHz cavities in the E-XFEL**
 - Beam measurements in 1.3 GHz cavities in the E-XFEL injector

- Summary

Spectra of E-XFEL 1.3 GHz cavities: First 5 Cryo-modules

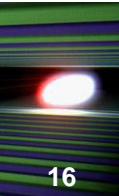

- Check modes of interest
 - Dipole modes at ca. $1.7 \text{ GHz} \pm 10 \text{ MHz}$ for beam position measurement
 - Monopole modes at between ca. 2.435 and 2.465 for beam phase measurement

- Data from cavity database

Spectra of E-XFEL 1.3 GHz cavities: First 5 Cryo-modules: Q vs. Frequency

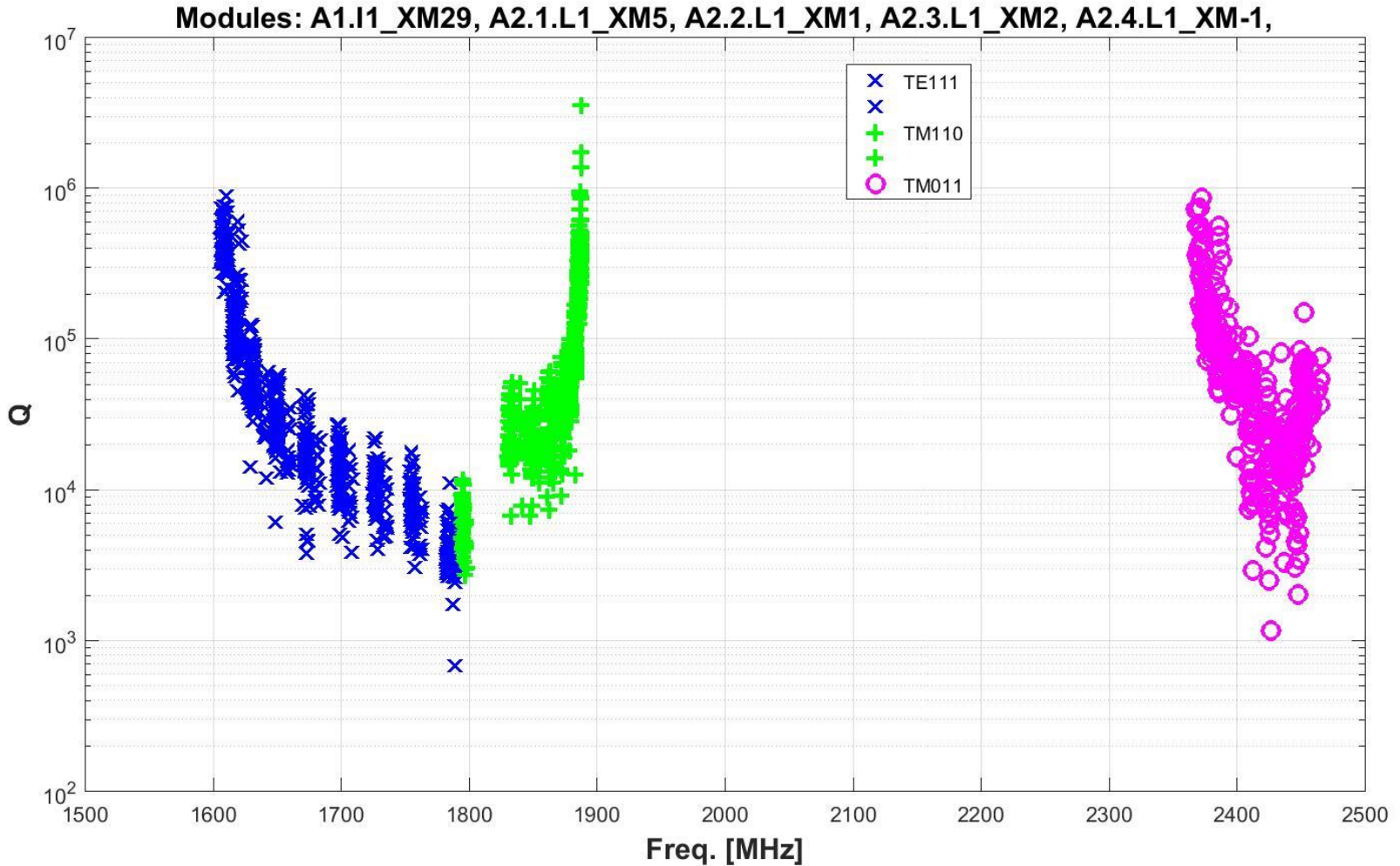
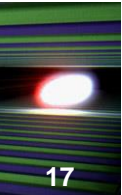

First 5 E-XFEL Modules: Q vs. Frequency: TE111-6 and TM011-7 to 9

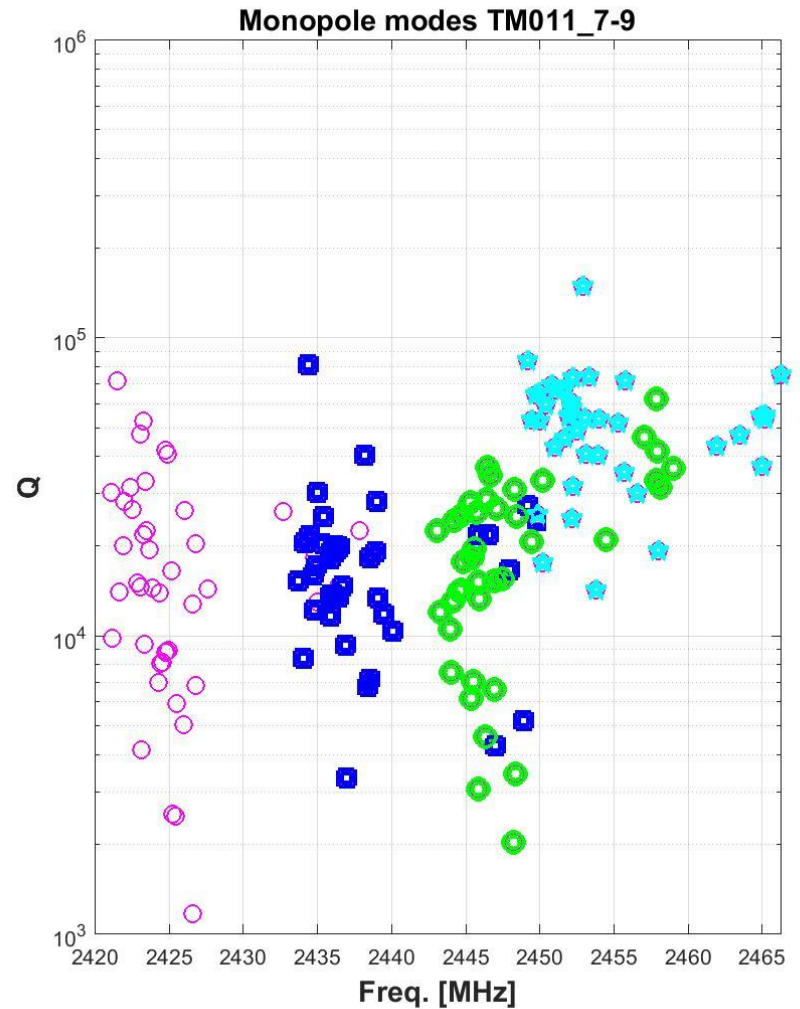
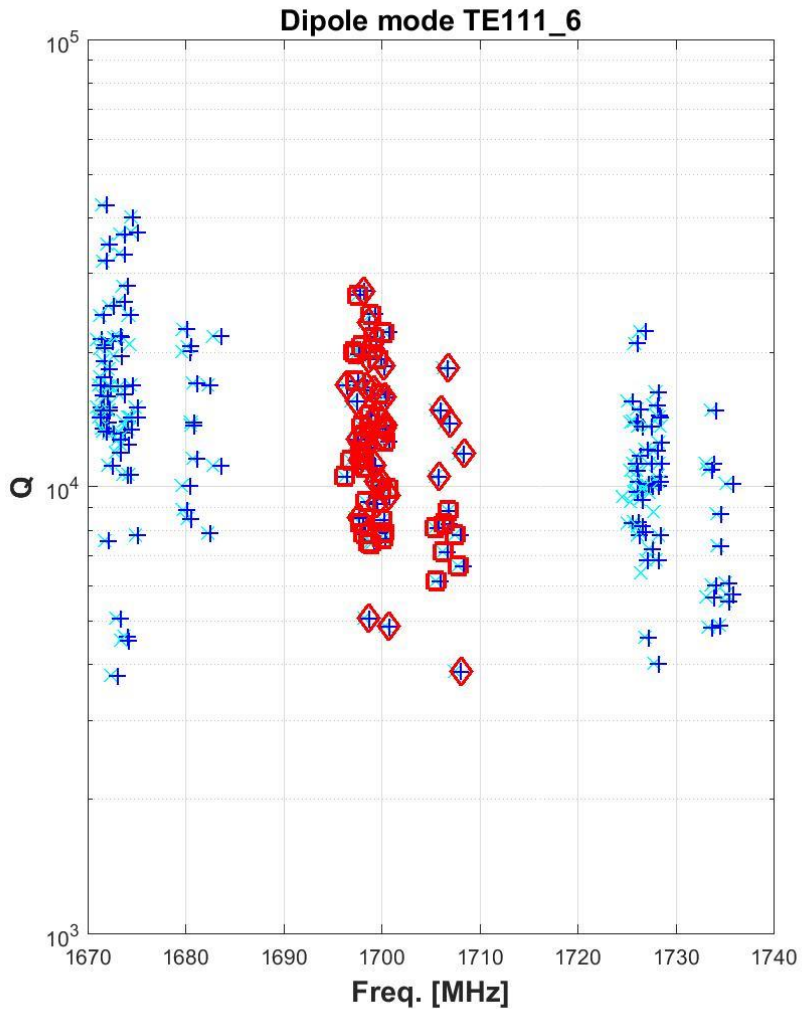
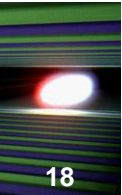

First 5 E-XFEL Modules: Frequency vs. Cavity

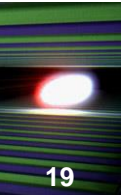

HOM frequencies in E-XFEL cavities in first 5 modules

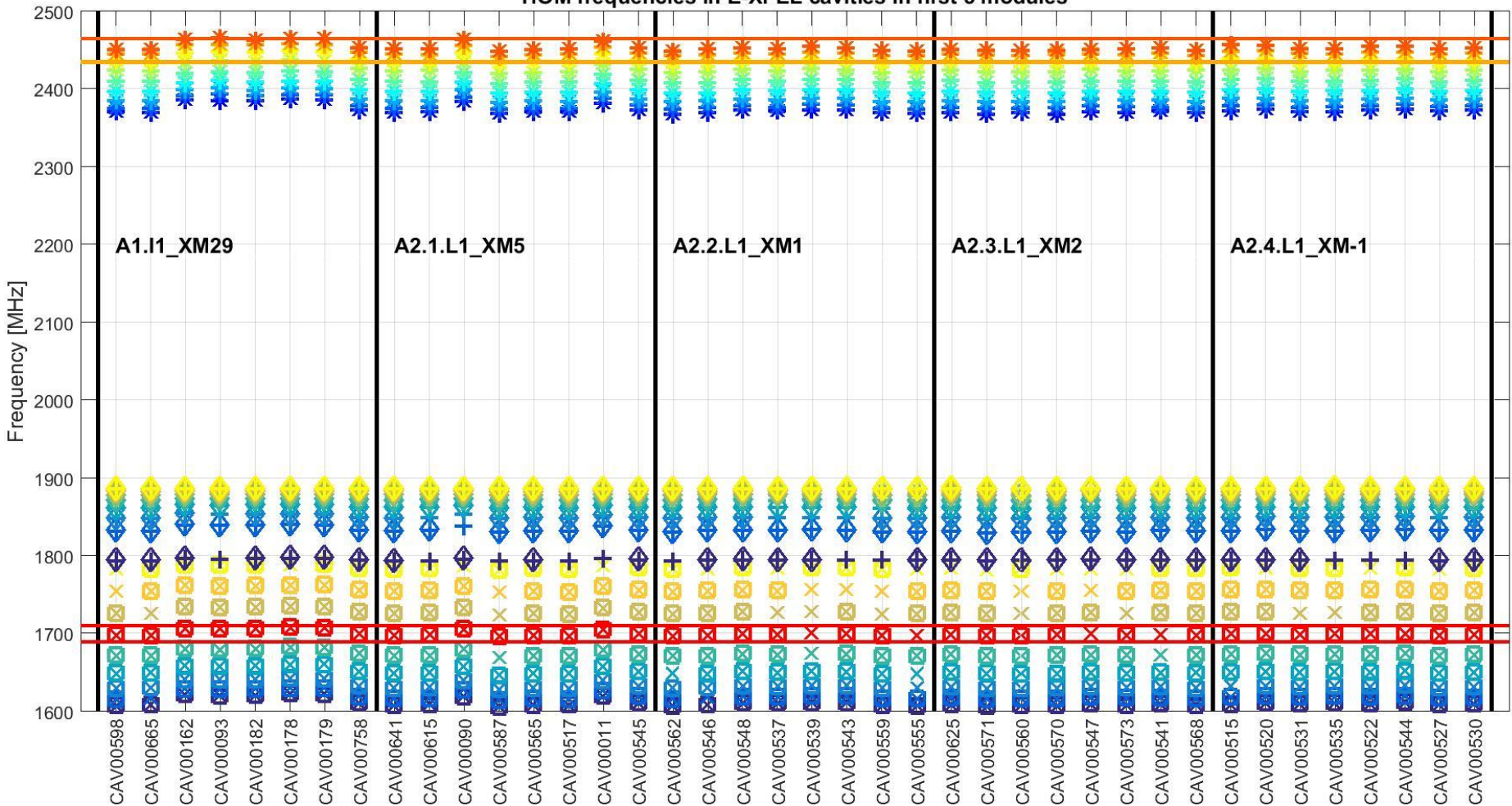

First 5 E-XFEL Modules: Frequency vs. Cavity: TE111-6

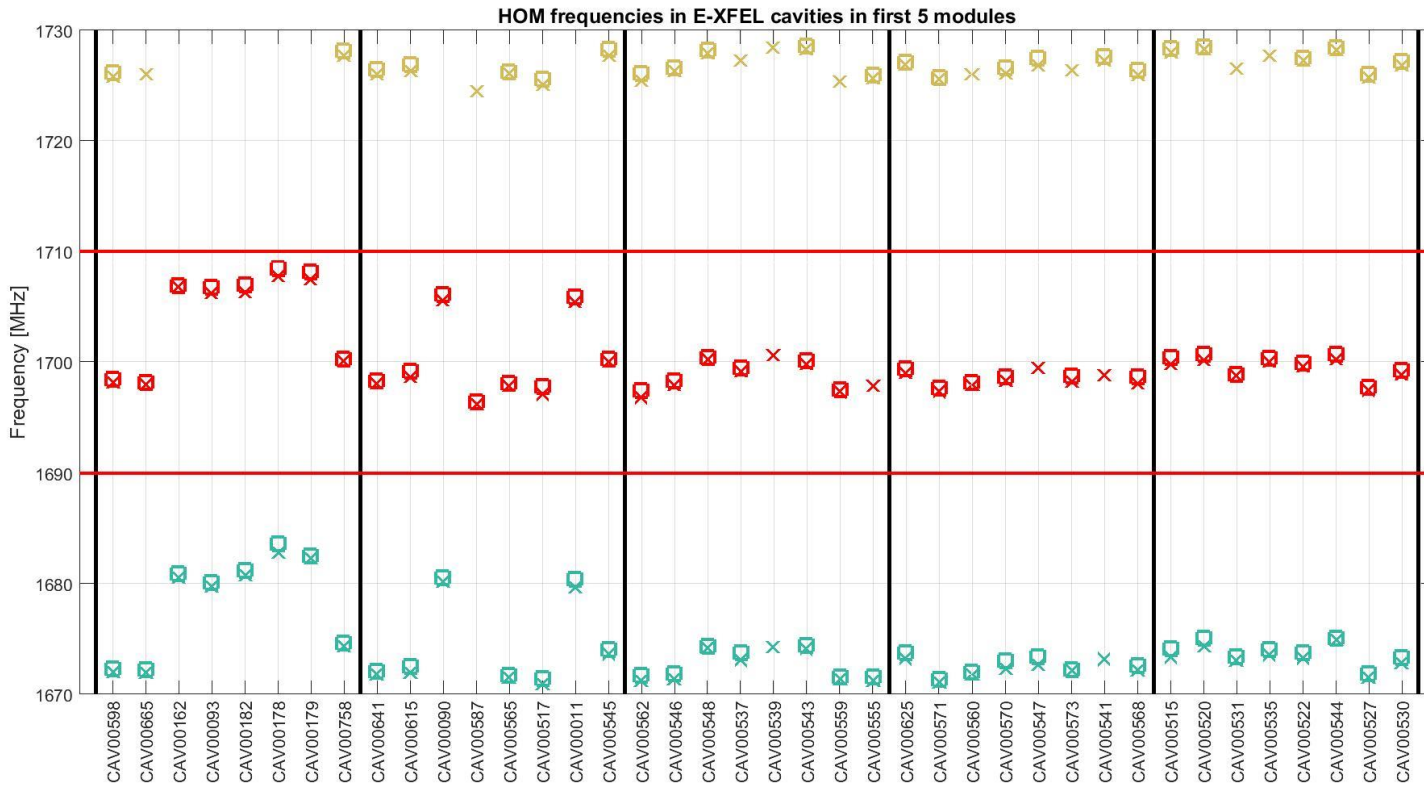
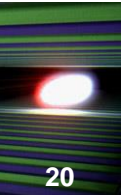

First 5 E-XFEL Modules: Frequency vs. Cavity: TM011-7 to 9

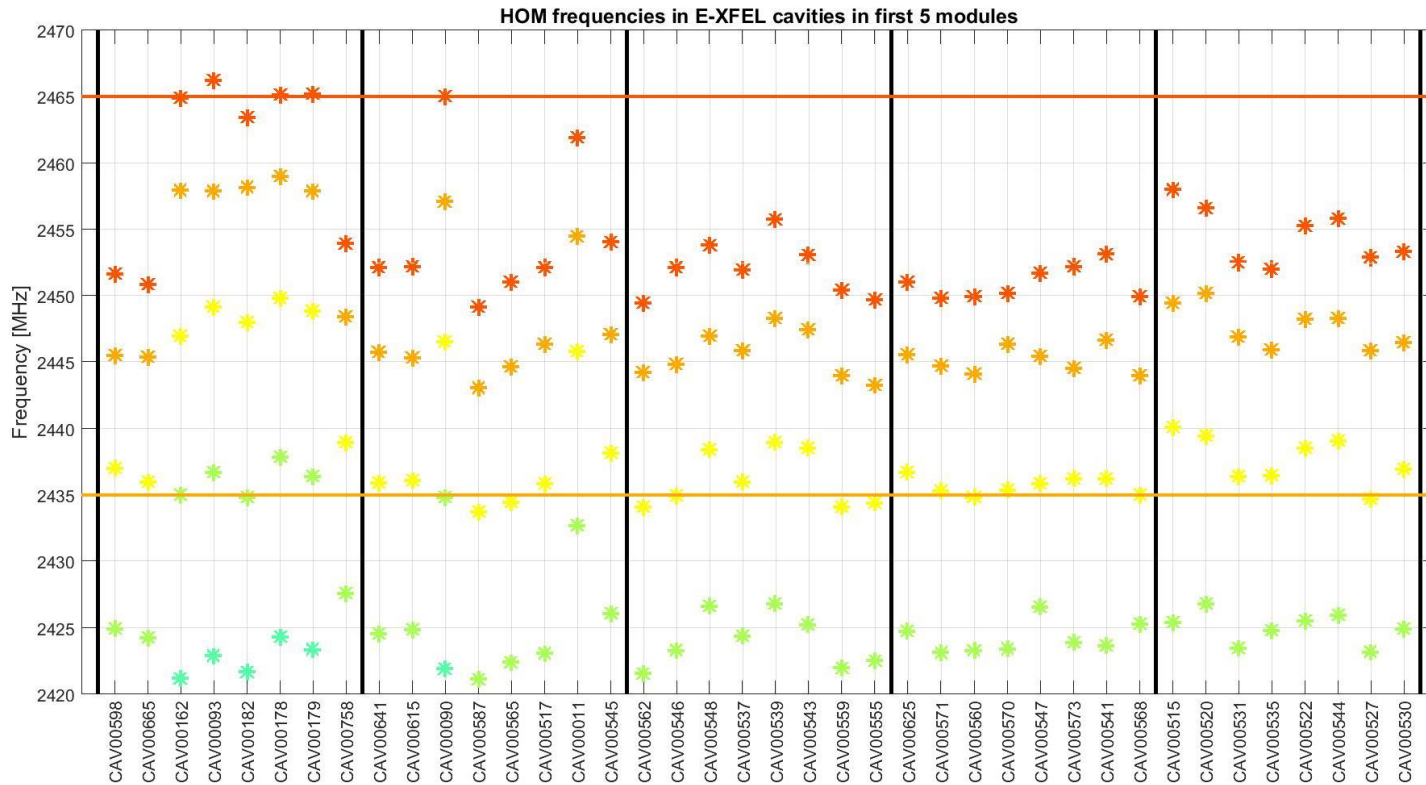
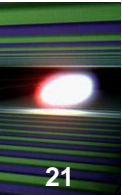

Spectra of E-XFEL 1.3 GHz cavities: First 5 E-XFEL Modules: Conclusions

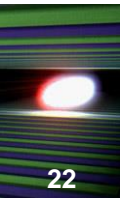

- Spectra of several cavities shifted
- Cavities were produced by 2 companies
- All cavities with shifted spectra are from one company
- Nevertheless still within filter of HOM electronics

- HOM-based diagnostics in SC accelerating cavities
 - Principle
 - Experience at FLASH

- The European XFEL
 - Spectra of 1.3 GHz cavities in the E-XFEL
 - **Beam measurements in 1.3 GHz cavities in the E-XFEL injector**

- Summary

Beam measurements in the E-XFEL injector: 1.3 GHz Cavities

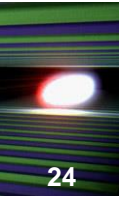

- Measured spectra of 8 cavities of the 1.3 GHz cryo-module in the first E-XFEL injector
- Measured their dependency on the beam position
- Used a Tektronik Real-Time Spectrum Analyzer (RSA)

Beam measurements in the E-XFEL injector: HOM Spectra

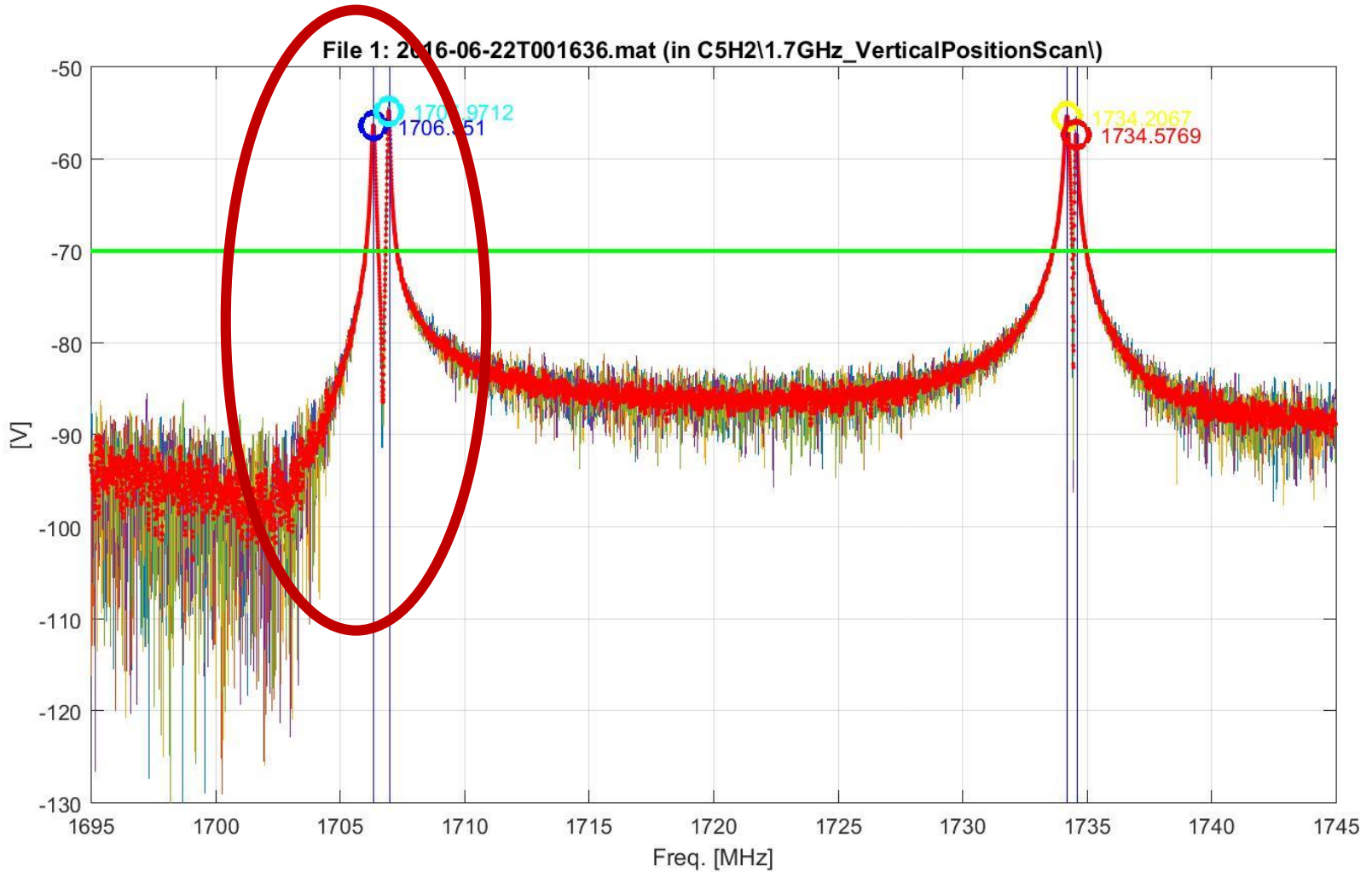
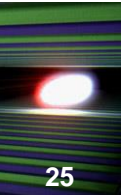

Beam measurements in the E-XFEL injector: HOM Spectra Variation with Beam Position

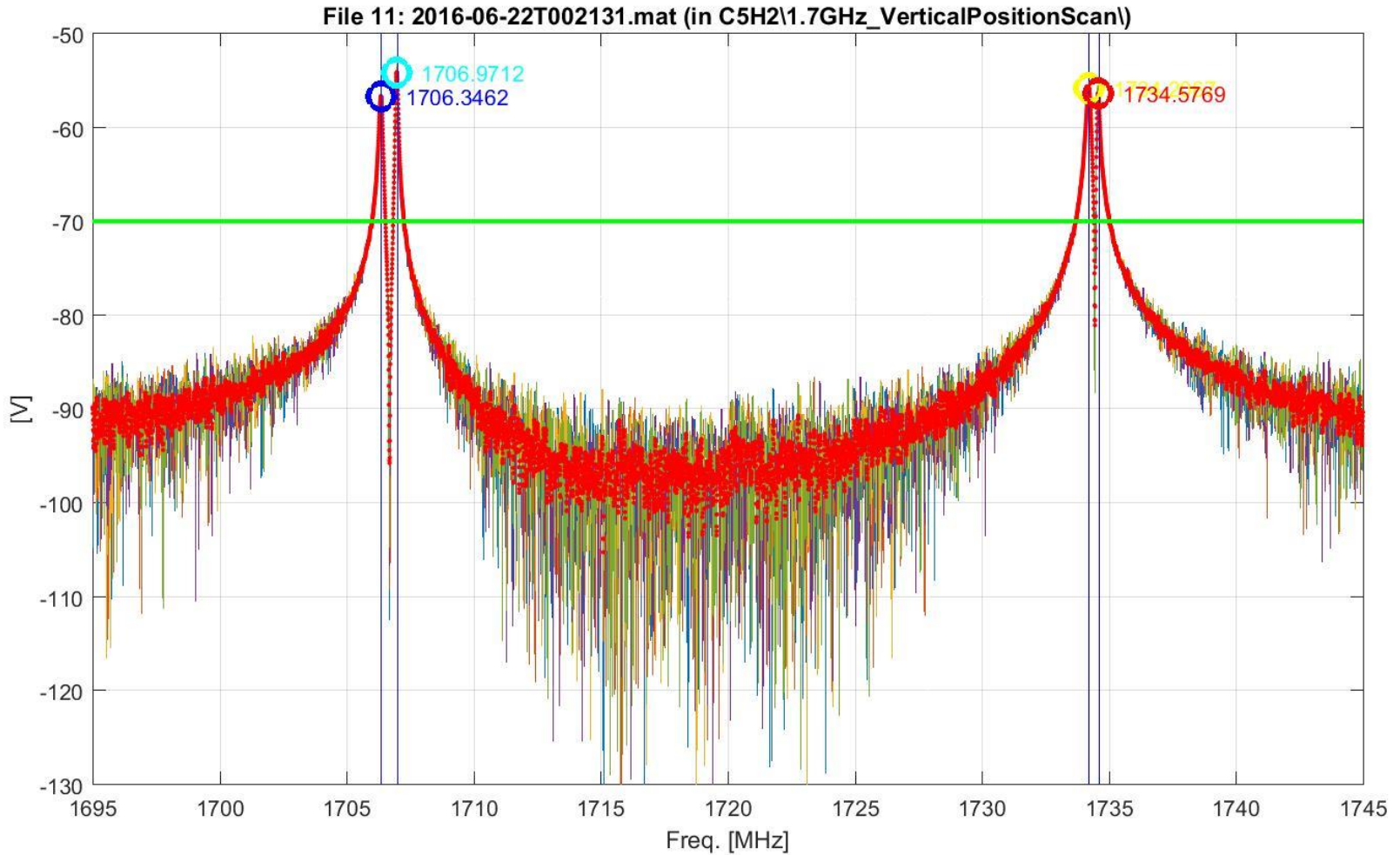
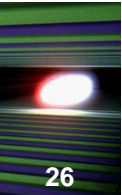

Beam measurements in the E-XFEL injector: 2D-Scan: Cavity 5, both HOM Couplers

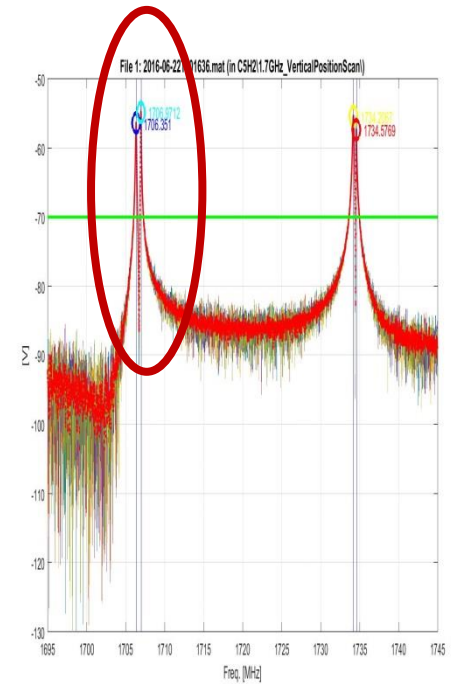
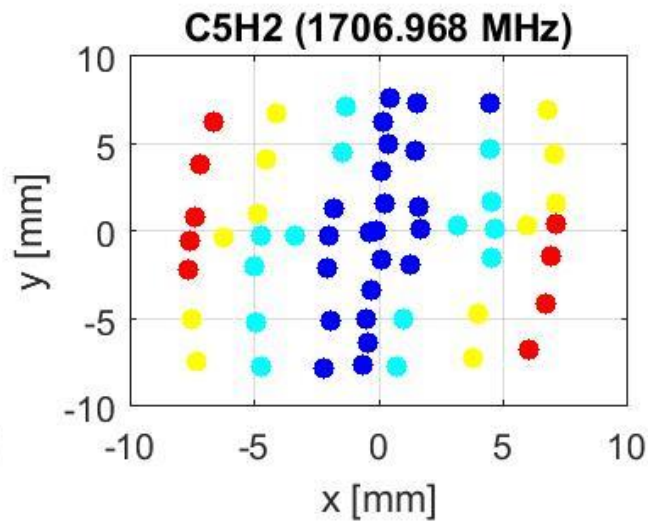
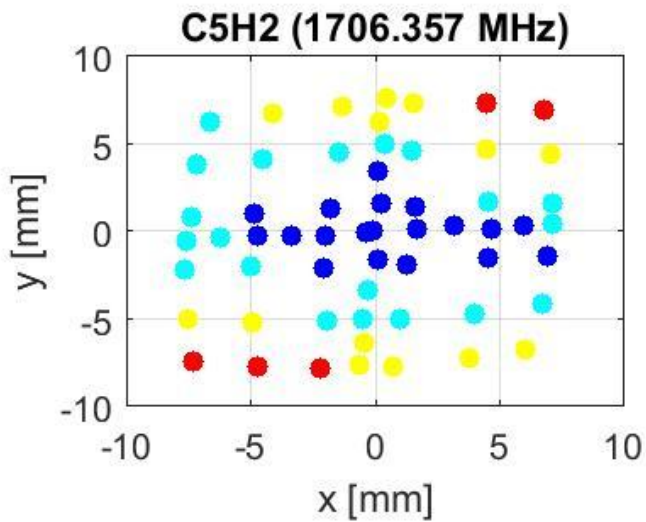
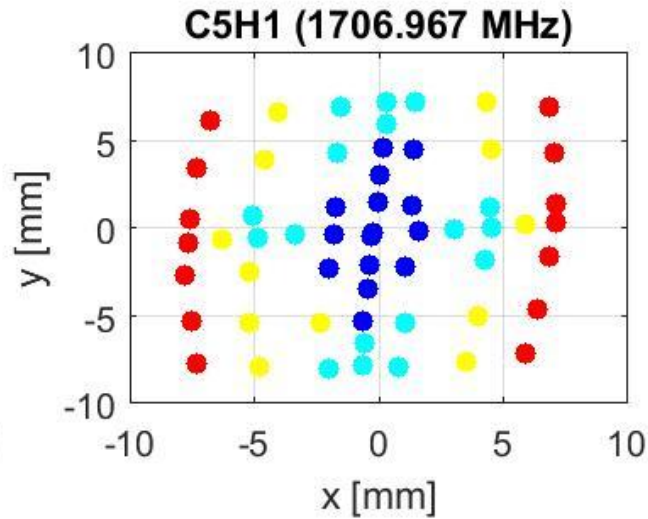
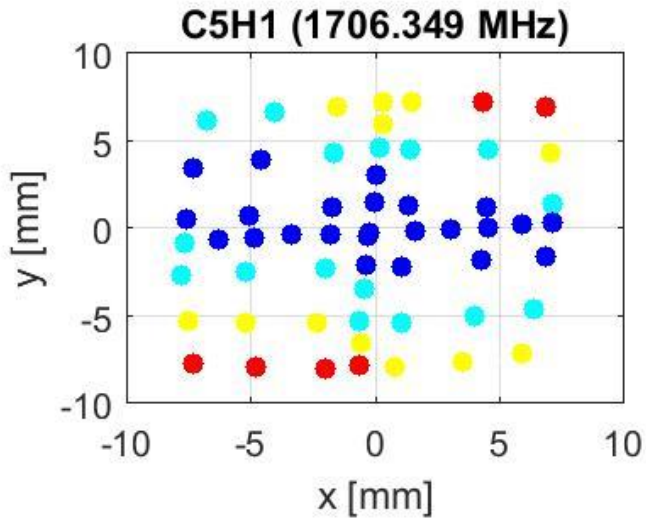
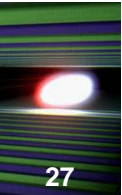

Beam measurements in the E-XFEL injector: 2D-Scan: Cavity 5, both HOM Couplers

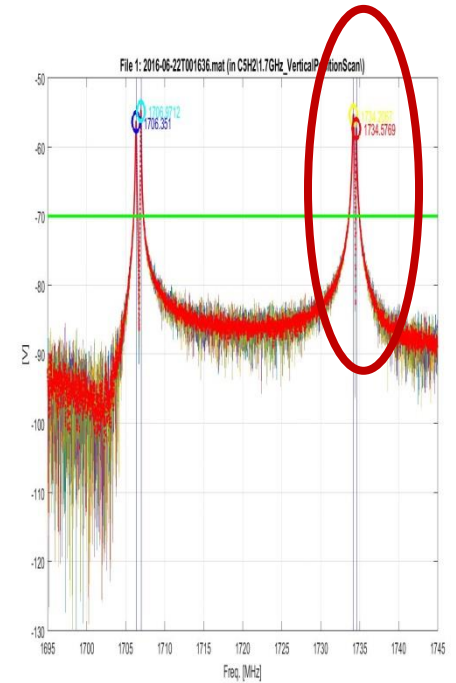
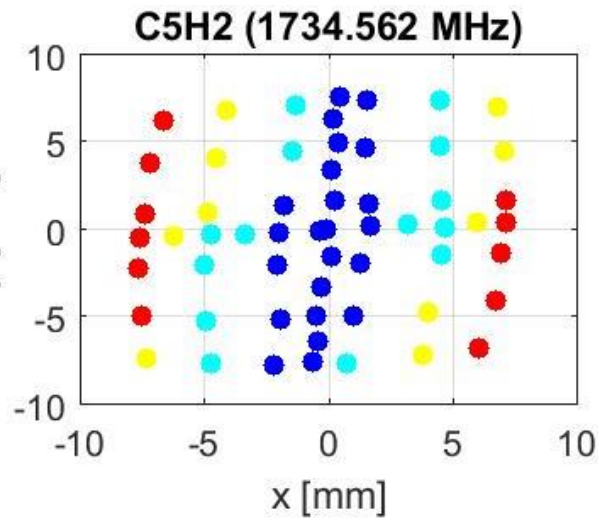
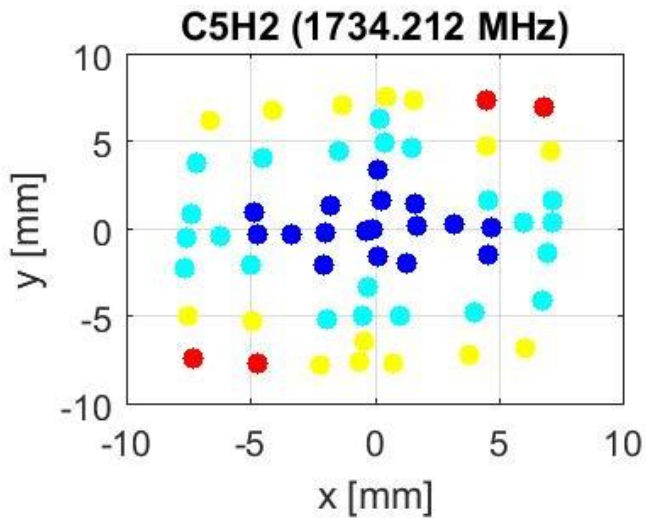
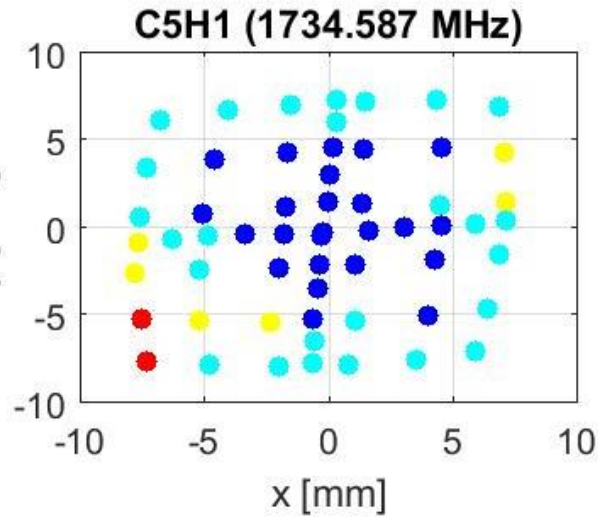
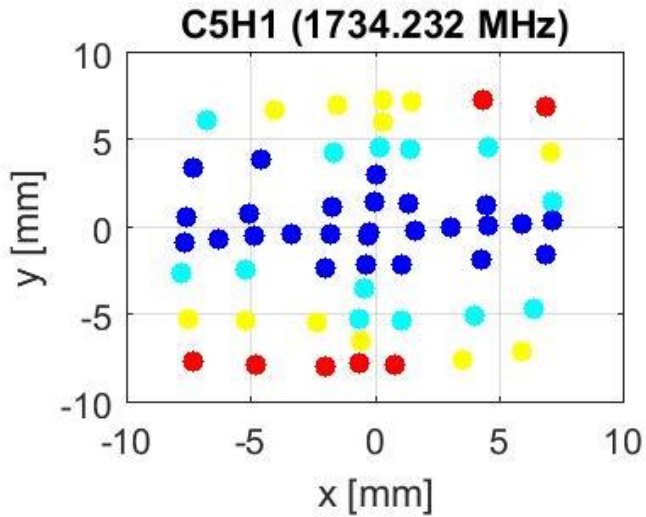
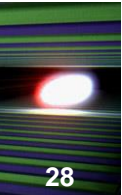

Beam measurements in the E-XFEL injector: Monopole Modes

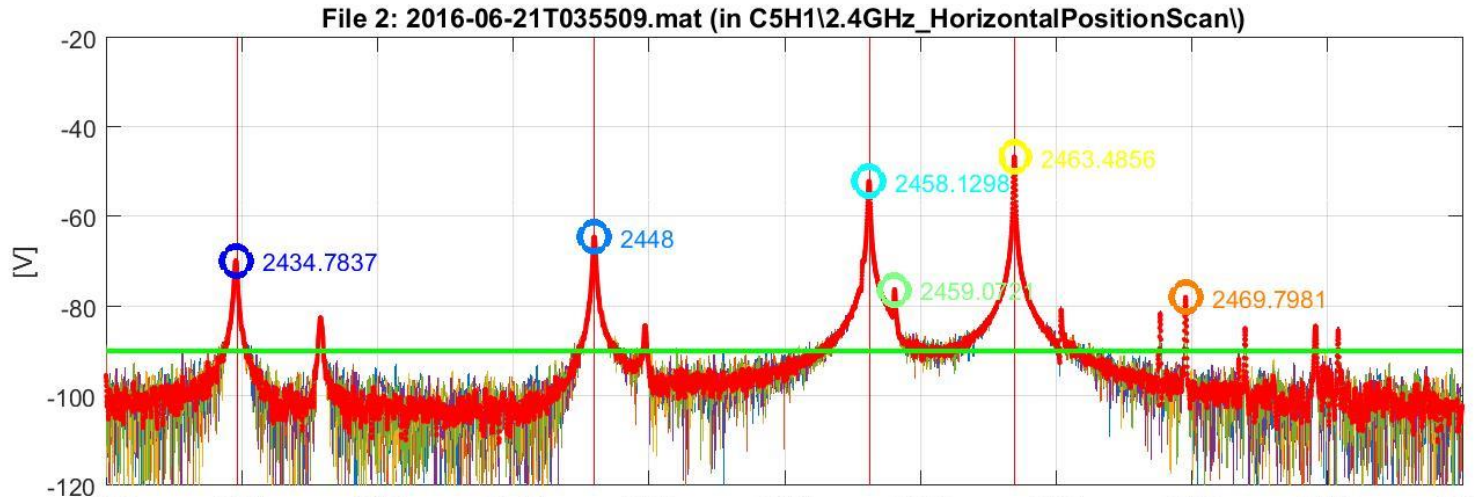
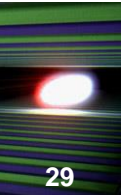

C5H1

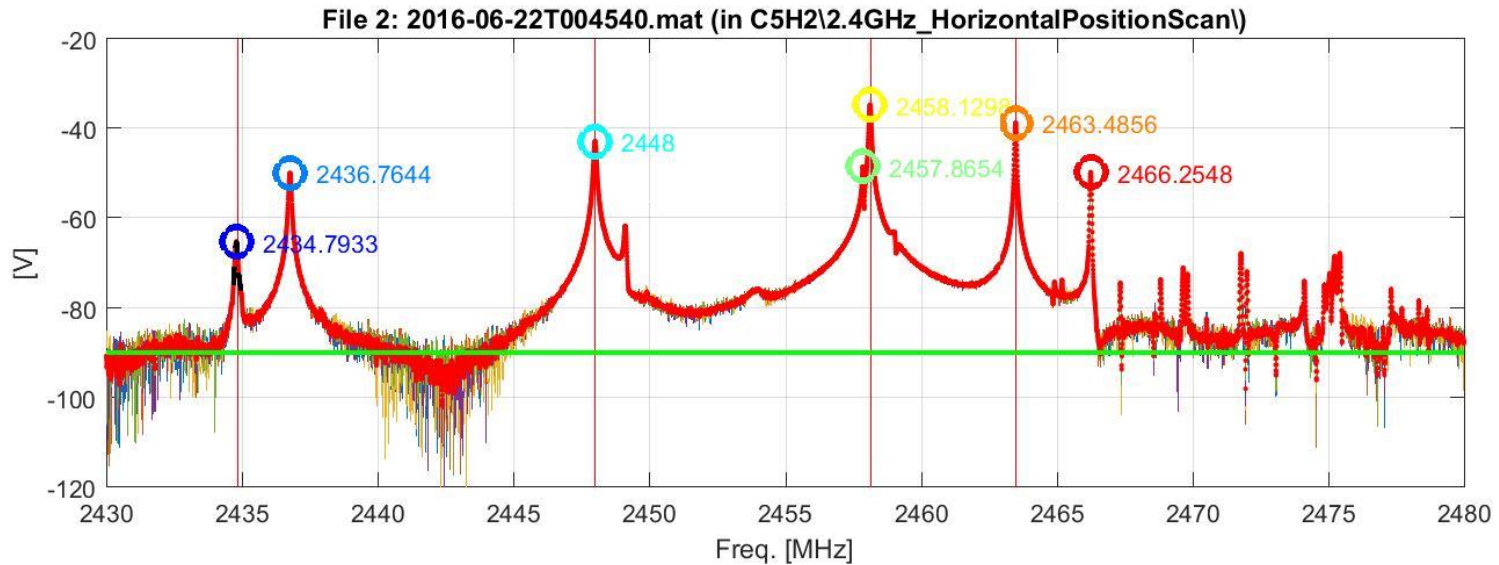

C5H2

Beam measurements in the E-XFEL injector: Conclusions

- Based on dipole signals can
 - Align the beam
 - Reduce excited dipole modes and therefore reduce their effect on the beam
 - Measure the beam position
 - Measure the cavity alignment in the cryo-module

- Monopole modes
 - Unidentified peaks observed, with no dependence on beam position

- HOM-based beam diagnostics planned at the E-XFEL based on experience at FLASH
- Spectra of first 5 E-XFEL 1.3 GHz modules
 - Some cavities have systematic shift of spectra
- Beam measurements in 1.3 GHz Cavities
 - Data recorded for all 8 cavities of the injector
 - Linear variation of dipole modes with beam position
 - Plans to calculate cavity alignment
 - Talk by Thorsten Hellert (for FLASH)
- First measurements on beam phase
 - Talk by Liangliang Shi

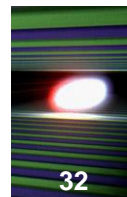

- Talk based on work of many people from several institutes
 - SLAC, CEA, FNAL, University of Rostock, University of Manchester, Cockcroft Institute, DESY

- Part of the work is currently made under EuCARD-2, Grant Agreement 312453
 - WP12 RF Technologies; Task 12.4 HOM-based Diagnostics
 - University of Manchester/Cockcroft Institute, Rostock University, DESY

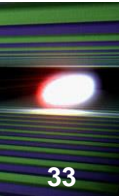

Thank you for your attention!